

Pneumatic Soft Start Valve and Electric Switching Valve S / SC / SSA

General

These valves increase the security of the machine operator and extend the machine's service life. The minimum operating pressure is 2 bar. Maximum operating pressure is 21 bar for the pneumatic and 10 bar for the electrical valve. Temperature range runs from 0 °C to 50 °C / 32 °F to 122 °F.

Pneumatic soft start valve

When connecting the air supply with the valve, the system is slowly filled with compressed air by an adjustable restrictor. The valve switches over to full scale operation when approx. 60% of the nominal pressure is reached. The pressure raising period can be set by adjusting the restrictor.

Note: The valve is not suitable for exhausting the system.

Electric soft start valve

As with the pneumatic soft start valve, the system is slowly filled with compressed air by an adjustable restrictor. However, switching over to full scale operation is carried out by the electrical switching valve, which receives the signal by an external pressure switch, for instance.

Electric 3-port/2-way valve

The electrically-operated 3-port/2-way valve is normally closed and directly controlled. It is capable of quickly pressurising and depressurising the system. The valve has a tapped exhaust.

Soft start switch-on/off valve

By the soft start switch-on/off valve the system is slowly filled with compressed air. Full scale pressurising or depressurising is achieved by the electric 3-port/2-way valve. The valve has a tapped exhaust.

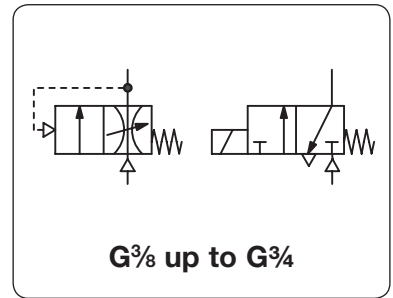

Description	For series	K _v value (m ³ /h)	Flow rate m ³ /h*1	Flow rate l/min*1	Connection thread G	Order number
-------------	------------	--	-------------------------------	-------------------	---------------------	--------------

Soft start and switching valve 24 V DC S / SC / SSA

Valve Type	Series	K _v value (m ³ /h)	Flow rate m ³ /h*1	Flow rate l/min*1	Connection thread G	Order number
pneumatic soft start valve	75	3.0	210	3500	G ³ / ₈	SSA 75-03
		3.4	240	4000	G ¹ / ₂	SSA 75-04
	105	6.1	432	7200	G ¹ / ₂	SSA105-04
		7.2	510	8500	G ³ / ₄	SSA105-06
electric switching valve	75	3.0	210	3500	G ³ / ₈	S 75-03M
		3.4	240	4000	G ¹ / ₂	S 75-04M
	105	5.6	432	6600	G ¹ / ₂	S105-04M
		7.2	510	8500	G ³ / ₄	S105-06M
soft start and switching valve	75	3.0	210	3500	G ³ / ₈	SC 75-03M
		3.4	240	4000	G ¹ / ₂	SC 75-04M
	105	5.6	432	6600	G ¹ / ₂	SC105-04M
		7.2	510	8500	G ³ / ₄	SC105-06M



Special options, add the appropriate letter

control voltage 230 V, 50 Hz

S Y

series	A	B (SSA)	B (S/SC)	C (SSA)	C (SSC)	D	E	ØF
75	56	120	203	38	56	18	42	5.5
105	77	133	218	47	67	21	64	6.5

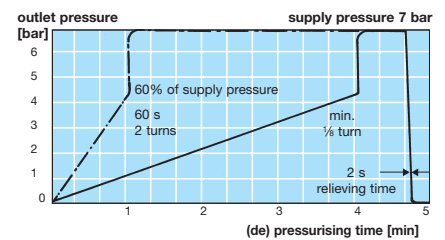
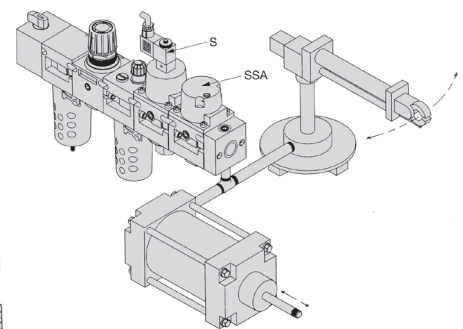
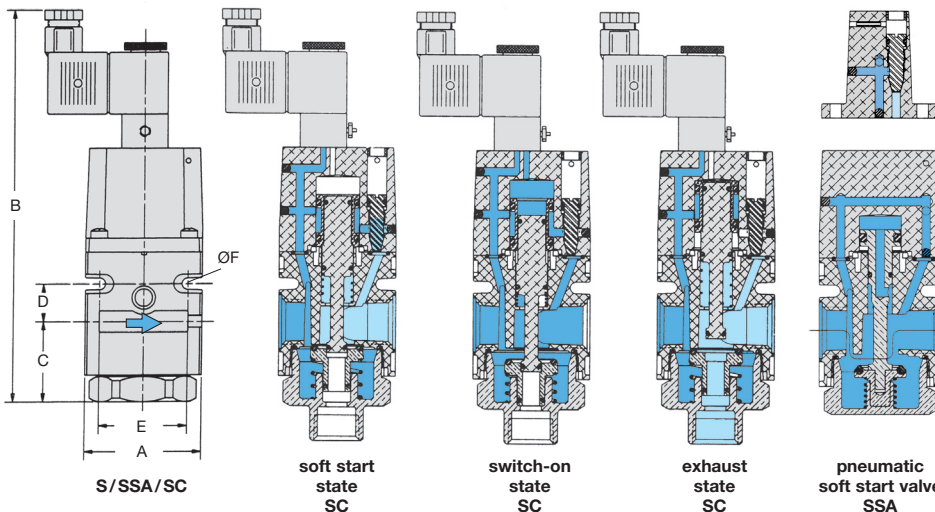

*1 at 7 bar supply pressure and 1 bar pressure drop

PDF CAD
www.aircom.net

Order example:
SSA75-03